

INSTRUCTION MANUAL

HM-50 Turret Milling Machine (240V) (X) 600mm (Y) 200mm (Z) 340mm



M160D

CONTENT

- 1、WARNING
- 2、USAGE
- 3、USE AND MAINTENANCE
- 4、MAIN PARAMENTERS
- 5、THE SYSTEM OF TRANSMITION AND CHANGED
SPEED
- 6、THE LUBRICATION OF MACHINE AND ROLLING
BEARING
- 7、ELECTRIC SYSTEM
- 8、TRANSPORT AND ATTENTION
- 9、SIMPLE MALFUNCTION & OBVIATION
- 10、PARTS DIVISION AND PARTS LIST

⚠ WARNING

1. Read and understand the entire instruction manual before operating machine.

2. Always wear approved safety glasses/face shields while using this machine.

3. Make certain the machine is properly grounded.

4. Before operating the machine, remove tie, rings, watches, other jewelry, and roll up sleeves above the elbows. Remove all loose clothing and confine long hair. DO NOT wear gloves.

5. Keep the floor around the machine clean and free of scrap material, oil and grease.

6. Keep machine guards in place at all times when the machine is in use. if removed for maintenance purposes, use extreme caution and replace the guards immediately.

7. Do NOT over reach. Maintain a balanced stance at all times so that you do not fall or lean against blades or other moving parts.

8. Make all machine adjustments or maintenance with the machine un-

plugged from the power source.

9. Use the right tool. Don't force a tool or attachment to do a job which it was not designed for.

10. Make certain the motor switch is in the OFF position before connecting the machine to the power supply.

11. Keep visitors a safe distance from the work area.

12. Never attempt any operation or adjustment if the procedure is not understood.

13. Keep fingers away from revolving parts and cutting tools while in operation.

14. Do not attempt to adjust or remove tools during operation.

15. Always keep cutters sharp.

16. Keep away from the turing handwheel, especially high speed.

17. Must pour the machine oil into the Gear Box and the power Feed (optional) rightly.

18. Failure to comply with all of these warnings may cause serious injury.

1 Attention

1.1 Inspection And Acceptance

Please check carefully when open the package and make sure no parts are missing.

1.2 Safety

Please read the operation manual carefully before the installation and adjustment of the machine. when finish the installation, check all the details and trial run the machine idly before put it into operation.

1.3 Caution

Keep in mind the safety measures for electrical and operating protection.

2. Work Environment

2.1 The elevation of workshop has to be 2000m or less.

2.2 No conductive dust allowed.

2.3 No explosive factor allowed.

2.4 No corrosive gas or steam which may corrode metal or damage the insulation.

2.5 Keep away from the source of impact or vibration.

3 Operation Instruction

3.1.1 Before starting the machine, read carefully the operation manual and be fully acquainted with all the details.

3.1.2 The operator should be familiar with all the rules and points of attention of running and maintaining the machine.

3.1.3 Remove all the anti-rust coating or grease from the machine. Fill the machine with lubricant. Run the machine from low to high speed and check if it is normal.

3.1.4 There's a reliable ground protection the ground wire must be connected properly before it in operation.

4. Lubrication

Lubricate the sliding and rotating part before trial run.

Pour NO.40 machine oil into the Gear Box and the Power Feed (optional). Till indicating through the oil level indicators then do a overall check.

Keep oil level above the mark.

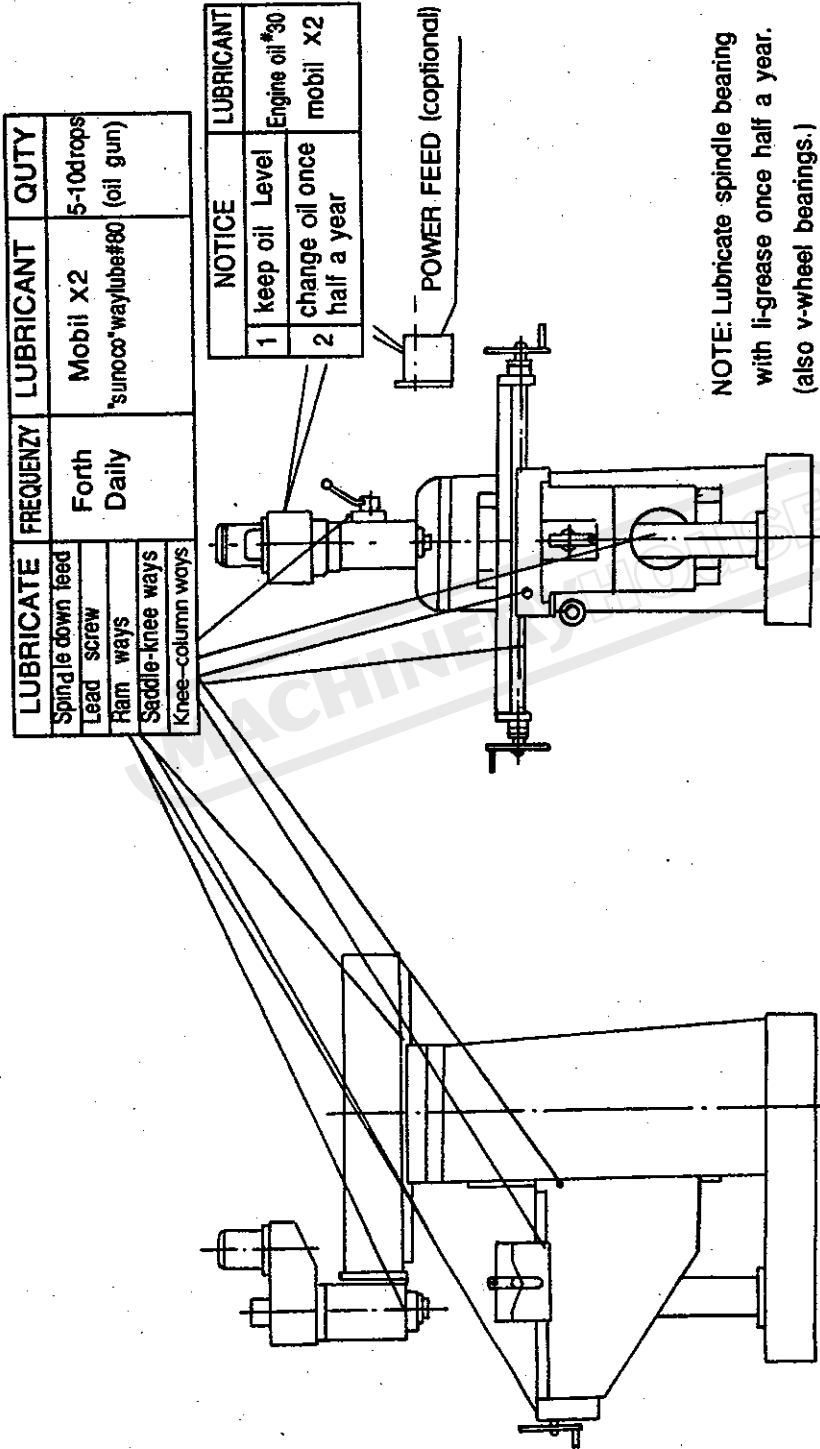

NOTE: Lubricate spindle bearing with li-grease once half a year. (also v-wheel bearings.)

LUBRICIATION

I USAGE

The machine is used for cutting metals and nonmetals. It's suitable to drill, mill, bore and widely use in the field for instrument, machining, repairing for cutting a single part or a batch of parts.

II USE AND MAINTENANCE

(Refer to chart1.)

1. The user must read the Operation Manual carefully, know structure and ability of every handle, the system of transmission and lubrication well.

2. Before operating, inspect the normal conditions of the column lock handle, the spindle sleeve and electric equipments. The ground line must be connect in the ground.

3. when the position of spindle Box to the working table need to be adjusted, two clamping shaft ① locating on the right side of Hoist—Descend sliding must be loosened firstly, then turn the hoist —descend handle in front of machine, to hoist or descend the working table to the idea position, finally clamp the clamping shaft ①.

4. A micro—feeding institute is applied to the machine, before using, pls turn the locking bolt ③ in right side to form the handle body with micro—gear, then turn the wheel ④ in front of the head, the micro—feeding can be realized. The spindle can revolve for tapping, through the universal switch equipped on the left side of the head.

But if the power motor is single phase, such function can't be realized.

5. The handle body must be separated from micro—gear during drilling and tapping. when drilling and tapping finished, loosen the handle ⑤ , the sleeve will reset automatically. the elastic torce can be adjusted after loosing the screw locating in the bottom of Spindle Box and turning the spring to different position. the spindle sleeve clamping handle ⑥ should be clamped for milling. To obtain the best effect, pls choose the 3 - blade vertical milling tool, at the most. the working table must be hoisted to the nearest position to the spindle when the 2—blade milling tool is used.

6. The boring function can be realized after equipping relative accessories. It is better to apply to micro—feeding during milling and boring.

7. The spindle box can turn $\pm 90^\circ$ in vertical plane. for turning the spindle box, pls firstly loosen the three tightening nut connecting with spindle box, turn the spindle to the needed angle through turning micro—worm ⑧ , finally pls tight the nut.

The Gear box can turn $\pm 45^\circ$ in vertical plane.

8. The cross—slide of spindle box can be realized through the ram moving. for cross—sliding, pls firstly loosen the two clamping bolts ⑨ locating on the right side of the ram, turn the gear shaft ⑩, to move the ram and spindle box, and tight the two clamping bolts.

9. The spindle box can turn 360° around the column in the horizontal plane. To realize this, pls firstly loosen the 4 pcs of clamping nuts (11) under the ram, turn the ram to the suitable position, finally tight the 4 pcs of clamping nuts.

10. The spindle's turn and revolve can be realized by the switch located in right side of Hoist—descend sliding.

11. The Horizontal milling can be realized by turn the vertical spindle box 90° . The spindle box must be turn 180° when the Tool shaft and jack applied for assistance.

12. If the machine doesn't work well or have irregular noise ,pls immediately shut off machine.

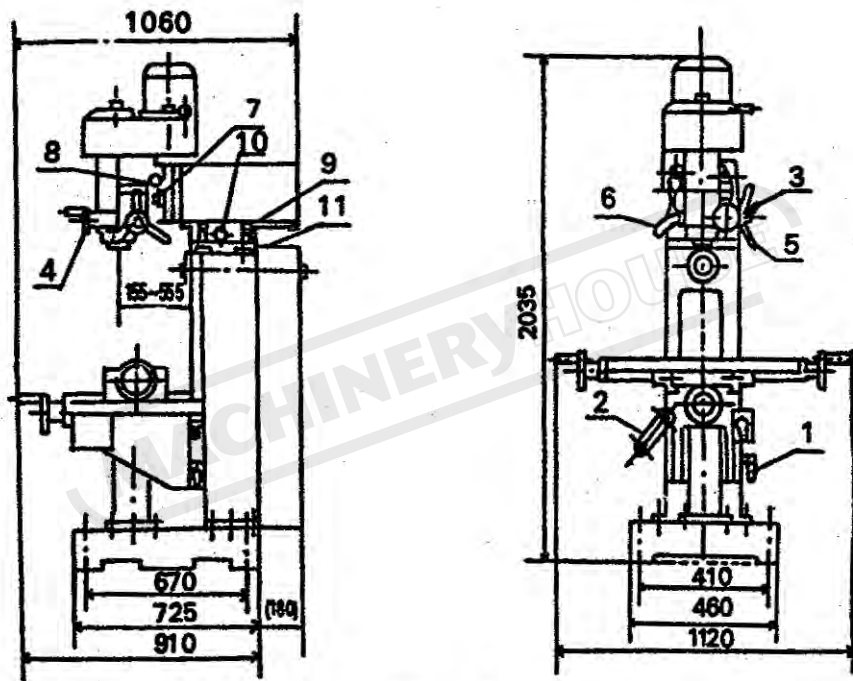

Chart 1

III MAIN PARAM

No	Model		HM50
	Ability		
1	Max. drilling dia.		30
2	Max. vertical milling dia.		25
3	Spindle taper		ISO30
4	Spindle speed		220—2400
5	Distance spindle to surface of Column		200---500
6	Distance spindle to table		80-430
7	Spindle travel		120
8	Table size		800 X 240
9	Table travel		350 X 210
10	Motor	1PH	YL90L-4,1.5KW
11	Over size		1100 X 1100 X1920
	N. W.		770 KG

III MAIN PARAM

No	Model Ability	HM52
1	Max. drilling dia.	30
2	Max. vertical milling dia.	25
3	Spindle taper	ISO30
4	Spindle speed	1PH 220—2400 60-1350
		3PH 230-1825 60-1350
5	Distance spindle to surface of Column	200---650
6	Distance spindle to table	20-370
7	Distance horizontal spindle to table	0-300
8	Spindle travel	120
9	Table size	800 X 240
10	Table travel	350 X 210
11	Motor	1PH YL90L-4,1.5KW
		3PH YD100L-8/4-0.85/1.5KW Y90L-4,1.5KW
12	Over size	1280 X 1100 X 1920
	N. W.	970 KG

IV THE SYSTEM OF TRANSMISSION AND CHANGED SPEED

1 . Transmission of power

a . HM50 machine transmit power from the motor to spindle through two V-belt .

b. HM52(1PH) machine transmit power from the motor to spindle through two V-belt .

c. HM52(3PH) machine transmit power from the motor to spindle through one V-belt .

2 . Vertical shaft :when changing speed , open the two side cover of upper spindle box , loosen the tightened bolt of motor , move handle on the rightside to loosen the belt, change belt to the position needed, remove motor and make belt fitted, tighten the tightened bolt and then work.

Horizontal shaft:when changing speed,open the cover of the cover of the rear vertical—column ,first loosen the nut lie between vertical—column and the surport of motor,then loosen nut that make belt loosed or tightened,adjust belt to the position required finally tighten the nut .

V THE LUBRICATION OF MACHINE AND ROLLING BEARING

1. Each rolling bearing to be lubricated with lubricating fat on time (prefer to chart—2).
2. Spindle, sleeve, column, table etc, should be lubricated at the right moment.

VI ELECTRIC SYSTEM

1. The electrical control system to be equipped in the left—side machine head. the control electrical system of horizontal spindle to be equipped under the right—front. Electrical circuit adopt the advanced international component to make up, which make the machine easy to operate and safe.

VII TRANSPORT AND ATTENTION

1. While transporting machine, must be careful to carry and put down.
2. In one year, we'll make promise to provide aftersales service.
3. Before Use the machine, the power feed the spindle's running and the coolant's running must be the same direction as the label. Otherwise two phase of power cord must be exchanged. (power feed and coolant system is optional accessories.)

VIII SIMPLE MALFUNCTION & OBVIATION

1. If the motor does not turn, please inspect it is right to connect wire or check electrical source.

2. If the radial run out of spindle is big with noise and heat, please inspect wether spindle is too loose.

pls spindle the nut on the spindle assembly to be fittest.

3. When the machine wobble, pls check the motor mount and lever lock nut screw, machine head surport on the spindle, if loosing, pls adjust and lock.

4. It is difficult for the spindle to rise, fall or not replacing, pls inspect wether there is scrap iron and other. something in the connection between spindle sleeve and gear shaft and fatigue of spindle, If finding them, pls clean them and apply oil and adjust spring to fittest.

5. If the knee table slide carrige does not rise steadily with noise, the table is steady, pls confirm wether wedge ship loose or not, and clean scrap iron. add oil adjust wedge ship to fittest.

6. If there is noise in gear box, pls stop machine immediately to conform the position you require, then check that the oil meet standard.

7. Prohibited maintaining the machine with electric.

NOTICE

I : The spindle box that transmitted by the belt can be swivled at 90° (by gear $\pm 45^\circ$). when operating, pls loose the three retaining nut and pay attention these nutes need only 1 pitch, then swivle scew lever by socket headscew wrench (s21—24) to make the spindle box swivle to the place required (clockwise turn the nut, the spindle box will counter clockwise turn, or otherwise), while turning, pay attention to the following item:

i: While the spindle box turn from horizontal position clined position to vertical position pls help push the upper of spindle box and gently twitter it.

ii: While the spindle box turn from vertical position to horizontal position or clined position, pls push the upper of spindle box with hand and twitter it gently.

II : The rotary table (optional) can swivle at 45° when operate, first loose two screw of back way cover and remove the way cover. Then loose the four nut. turn the table to the direction you want.

III . Adjust the perpendicular between spindle and table gauge magnetize on end face of spindle. Tracing pin turn 360° about dia Φ 250—300mm on the surface of the table. This is perpendicular between spindle and table if measuring range is variable between 0 and 0.02mm.

ROLLING

BEARING

ITEM	BEARING	MODEL	QTY.	
			HM50	HM52
1	Single dustdefence radial ball bearing	60109/p6	2	2
2	Single dustdefence radial ball bearing	60109/p6	1	1
3	Single tapered roller bearing	2007110/p6	1	1
4	Single dustdefence radial ball bearing	60103 (3PH)		2
		60103 (1PH)	2	4
5	Single tapered roller bearing	2007111/p6		1
6	Single tapered roller bearing	7308E/p6		1
7	Single dustdefence radial ball bearing	60105		2

(See N0.2a,2b,2d on the next page.)

Rolling bearing position

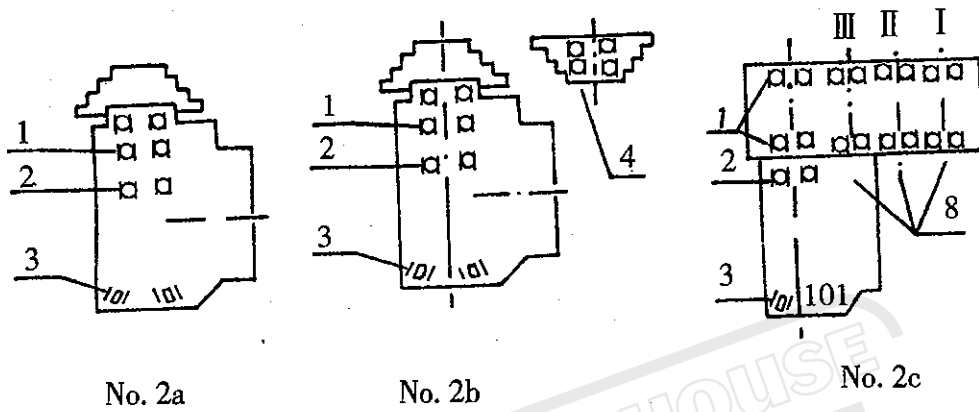

No. 2a

No. 2b

No. 2c

Chart 2

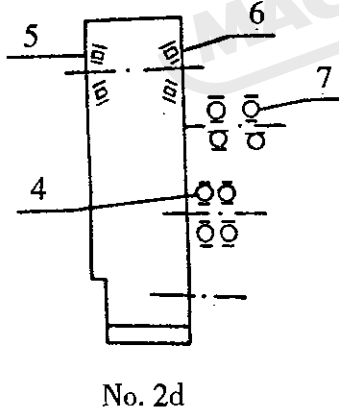

No. 2d

PARTS DIVISION AND PARTS LIST

A: COLUMN PART

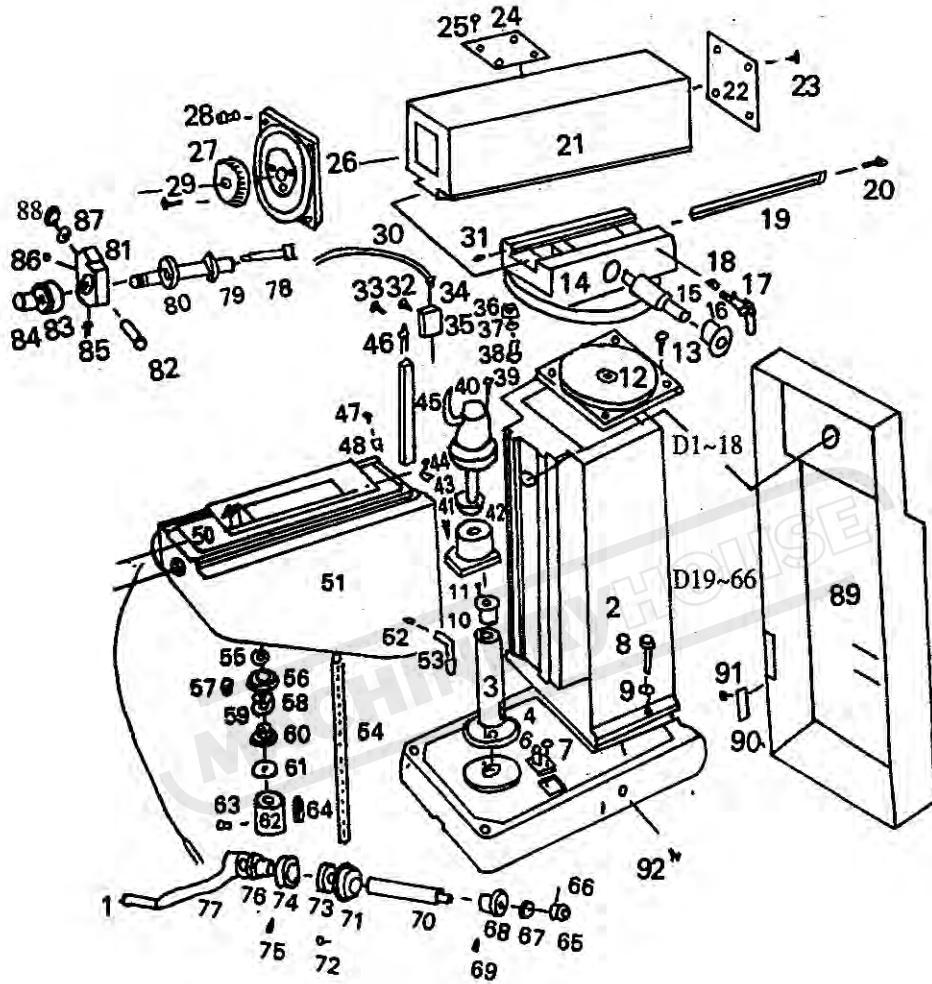

(optional accessory: cooling system)

B: Rotary table (optional)

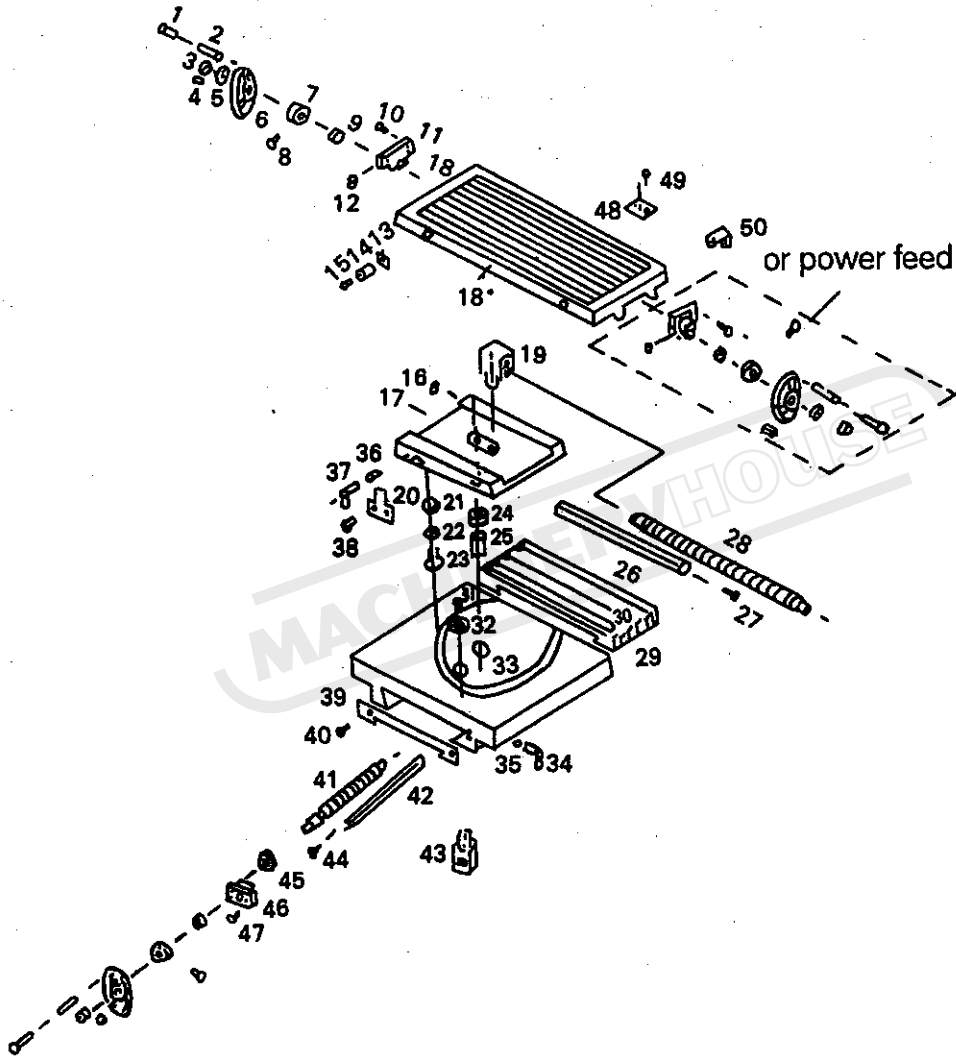

C: HEAD PART--- 1PH

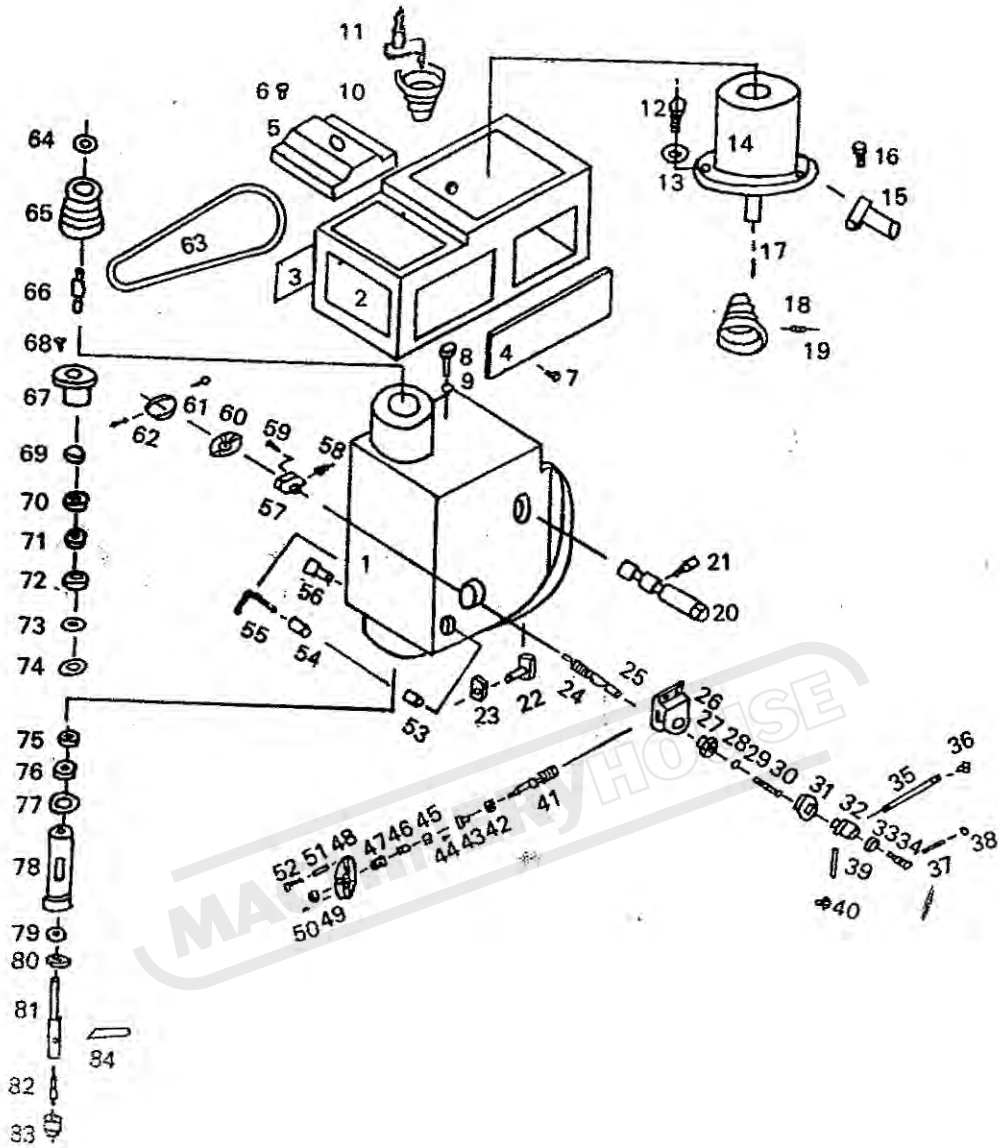

D: HORIZONTAL SPINDLE PART

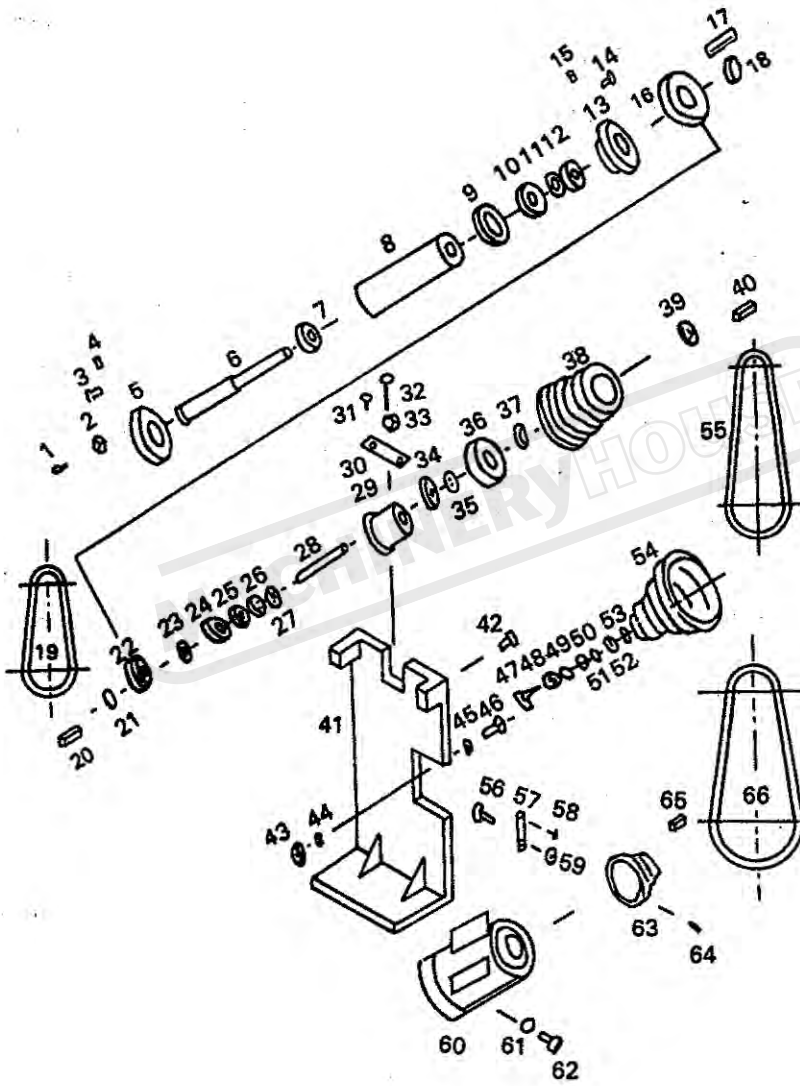

E: Gear box

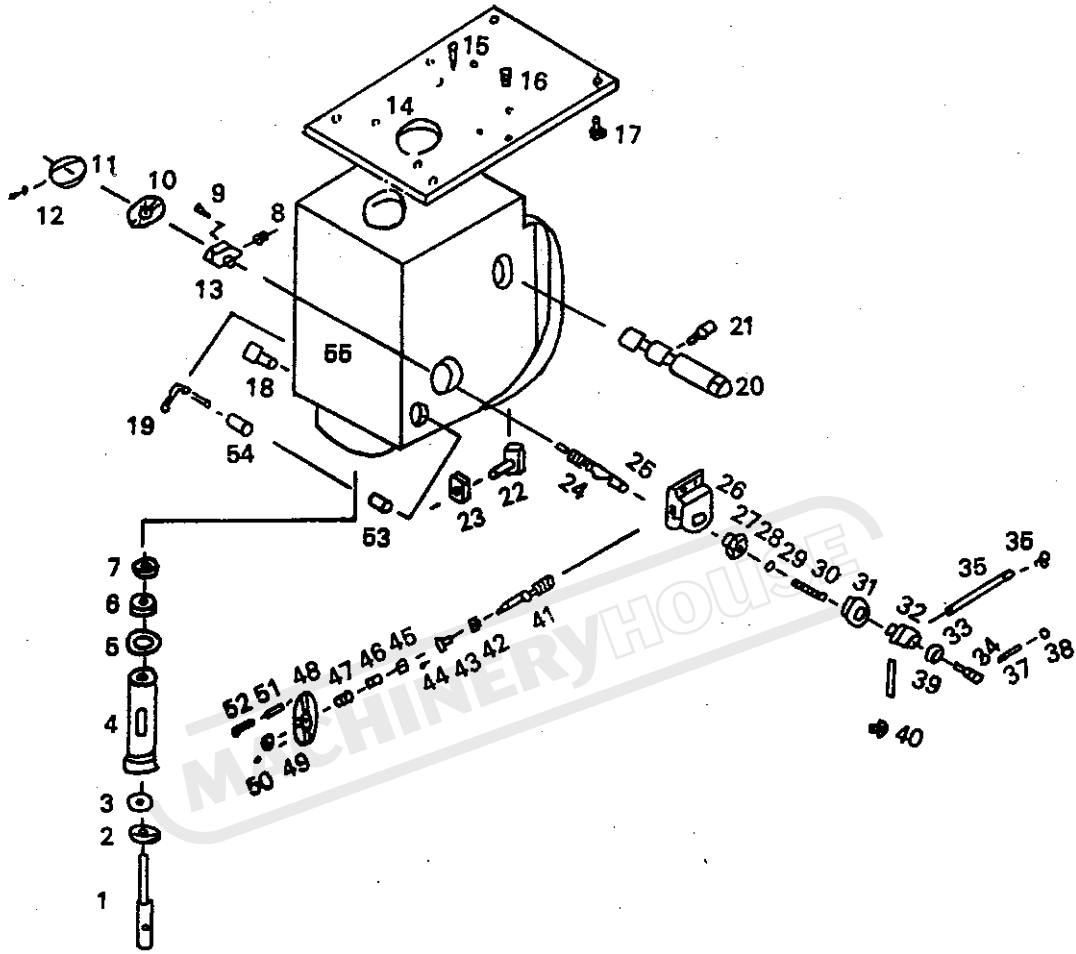

F: Gear head

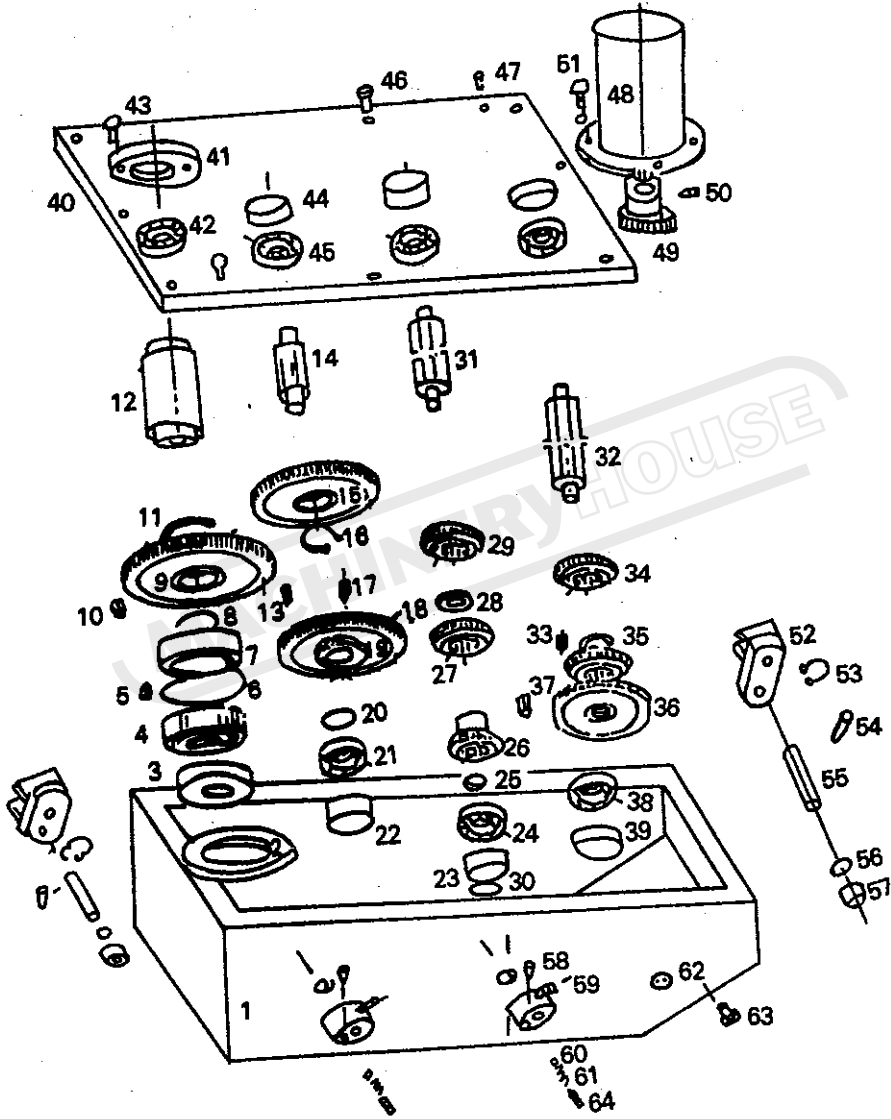

G: Table

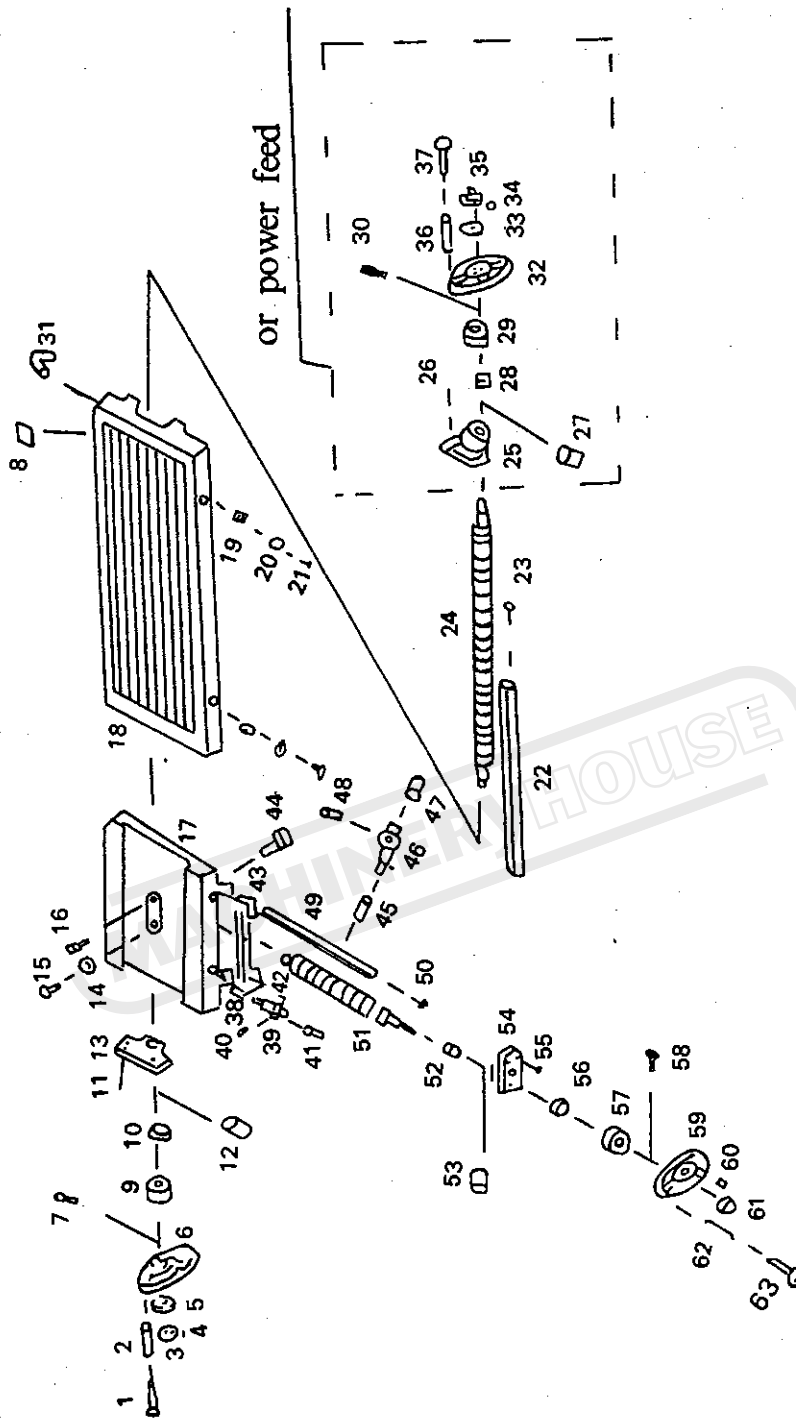

NUMBERP	NAME	QUANTITY
A1	BASE	1
2	COLUMN	1
3	ELEVATING SCREW HOUSING	1
4	SCREW	4
5	WASHER	4
6	CONNECT TUBE	1
7	SCREW	2
8	BOLT	6
9	WASHER	6
10	COLLAR	1
11	SCREW	4
12	HOLD SURREORT	1
13	SCREW	6
14	AROUND BRACKET	1
15	FEED SHAFT	1
16	COLLAR	1
17	CLAMP BOLT	2
18	CLAMP BLOCK	2
19	BEVEL IRON	1
20	SCREW	1
21	OVERARM	1
22	COVER	1
23	SCREW	4
24	COVER	1
25	SCREW	4
26	HOLD BRACKET	1
27	GEAR	1
28	SCREW	4
29	BOLT	2
30	NOZZLE	1
31	OIL CUP	2

NUMBERP	NAME	QUANTITY
32	SCREW	2
33	BOLT	1
34	CONNECT TUBE	1
35	HOLD BRACKET	1
36	NUT	4
37	WASHER	4
38	T BOLT	4
39	BOLT	4
40	ELECTRIC PUMP	1
41	BOLT	4
42	SUPPORT	1
43	DUST COVER	1
44	SCREW	2
45	BEVEL IRON	1
46	ADJUST SCREW	1
47	SCREW	2
48	WIPER PLATE	1
49	WIPER PLATE	1
50	WIPER PLATE	2
51	KNEE	1
52	CLAMP BLOCK	2
53	CLAMP BOLT	2
54	HOIST DESCEND LEAD SCREW	1
55	CIRCULAR NUT	2
56	CONICAL GEAR	1
57	KEY	1
58	BALL BEARING	1
59	ADJUST WASHER	1
60	COLLAR	1
61	BALL BEARING	1
62	NUT	1

NUMBERP	NAME	QUANTITY
63	SCREW	1
64	KEY	1
65	CONECAL GEAR	1
66	PIN	1
67	WASHER	1
68	COLLAR	1
69	SCREW	1
70	SHAFT	1
71	COLLAR	1
72	SCREW	4
73	BALL BEARINGP	1
74	SCALE RING	1
75	SCREW	1
76	COLLAR	1
77	HANDLE	1
78	LIFT BAR	1
79	TOOLHOLDER	2
80	CUTTER BAR COLLAR	10
81	SUPPORT	1
82	BOLT	1
83	COLLAR	1
84	NUT	1
85	SCREW	1
86	OIL CUP	1
87	WASHER	1
88	NUT	1
89	BEHIND COVER	1
90	HINGE	2
91	SCREW	16
92	SCREW	1

NUMBERP	NAME	QUANTITY
B1	HANDLE	3
2	HANDLE COLLAR	3
3	NUT	3
4	KEY	3
5	WASHER	3
6	HAND WHEEL	3
7	SCALE RING	3
8	SCREW	3
9	BEARING	3
10	SCREW	10
11	SUPPORT	2
12	OIL CUP	3
13	SCREW BRACKET	2
14	DOG	2
15	SCREW	2
16	OIL CUP	2
17	ROTARY BRACKET	1
18	TABLE	1
19	NUT	1
20	LIMIT ASSEMBLY	1
21	NUT	1
22	WASHER	4
23	T - BOLT	4
24	SHAFT MOUNT	1
25	SHAFT	1
26	LONG BEVEL IRON	1
27	ADJUST SCREW	1
28	LONGITUD INALLEAD SCREW	1
29	WAY COVER	

NUMBERP	NAME	QUANTITY
C1	SPINDLE BOX	1
2	MOTOR BASE	1
3	LEFT COVER	1
4	RIGHT COVER	1
5	PULLEY COVER	1
6	SCREW	4
7	SCREW	4
8	BOLT	6
9	WASHER	6
10	Center Pulley	1
11	Center Pulley Shaft <i>Parts</i>	1
12	BOLT	2
13	WASHER	1
14	MOTOR	1
15	HANDLE	1
16	BOLT	2
17	KEY	1
18	MOTOR PULLEY	1
19	HEADLESS SEAT SCREW	1
20	WORM GEAR	1
21	PIN	1
22	T BOLT	3
23	NUT	1
24	FEED SHAFT	1
25	KEY	1
26	WORM BOX	1
27	SCREW	3
28	BEVEL GEAR	1
29	RETAINING RING	1
30	SPRING	1
31	SCALE RING	1

NUMBERP	NAME	QUANTITY
32	HANDLE BRACKET	1
33	COVER	1
34	BOLT	1
35	HANDLE BAR	3
36	KNOB	3
37	HANDLE	1
38	HANDLE COLLAR	1
39	SCALE	1
40	RIVET	2
41	WORM GEAR	1
42	BALL BEARING	1
43	SMALL COVER	1
44	SCREW	3
45	BALL BEARING	1
46	COLLAR	1
47	SCALE RING	1
48	HANDLE WHEEL	1
49	HANDLE COLLAR	1
50	HANDLE	1
51	NUT	1
52	KEY	1
53	CLAMP BLOCK	1
54	CLAMP BLOCK	1
55	CLAMP HANDLE	1
56	SCREW	1
57	SPRING SEAT	1
58	SCREW	1
59	SCREW	1
60	SPRING PLATE	1
61	SPRING CAP	1
62	SCREW	2

NUMBERP	NAME	QUANTITY
D1	SCREW	4
2	KEY	2
3	SCREW	4
4	OIL CUP	1
5	COVER	1
6	SPINDLE	1
7	BALL BEARING	1
8	COLLAR	1
9	BALL BEARING	1
10	WASHER	1
11	WASHER	1
12	NUT	1
13	COVER	1
14	SCREW	4
15	OIL CUP	1
16	SPINDLE PULLEY	2
17	KEY	1
18	RETAINING RING	1
19	V BELT	2
20	KEY	1
21	RETAINING RING	1
22	WHEEL	1
23	BALL BEARING	1
24	BALL BEARING	1
25	BALL BEARING	1
26	COLLAR	1
27	BALL BEARING	1
28	SMALL SHAFT	1
29	COLLAR	1
30	SUPPORT	1
31	SCREW	2

NUMBERP	NAME	QUANTITY
32	BOLT	1
33	NUT	1
34	RETAINING RING	1
35	RETAINING RING	1
36	NUT	2
37	RETAINING RING	1
38	PULLEY	1
39	RETAINING RING	1
40	KEY	1
41	MOTOR BASE	1
42	SCREW	6
43	NUT	1
44	WASHER	1
45	WASHER	1
46	SMALL SHAFT	1
47	CONNECT	1
48	REAINING RING	1
49	BALL BEARING	1
50	COLLAR	1
51	BALL BEARING	1
52	RETAINING RING	1
53	RETAINING RING	1
54	PULLEY	1
55	V—BELT	1
56	ADJUST SCREW	1
57	SUPPORT	1
58	SCREW	1
59	NUT	1
60	MOTOR	1
61	WASHER	4
62	BOLT	4

E: GEAR BOX

NUMBERP	NAME	QUANTITY
E1	SPINDLE	1
2	DUST COVER	1
3	BEARING	1
4	SLEEVE	1
5	BEARING	1
6	WASHER	1
7	NUT	1
8	SCREW	1
9	SCREW	1
10	SPRING PLATE	1
11	SPRING CAP	1
12	SCREW	1
13	SPRING SEAT	1
14	BASE	1
15	PIN	2
16	SCREW	6
17	SCREW	6
18	BOLT	1
19	CLAMP HANDLE	1
20	WORM GEAR	1
21	PIN	1
22	T—BOLT	3
23	NUT	3
24	FEED SHAFT	1
25	KEY	1
26	WORM BOX	1
27	SCREW	3
28	BEVEL GEAR	1
29	CRESCENT RING	1
30	SPRING	1

NUMBERP	NAME	QUANTITY
31	SCALE RING	1
32	HANDLE BRACKET	1
33	COVER	1
34	BOLT	1
35	HANDLE BAR	3
36	KNOB	3
37	HANDLE	1
38	HANDLE COLLAR	1
39	SCALE	1
40	RIVET	2
41	WORM GEAR	1
42	BEARING	1
43	SMALL COVER	1
44	SCREW	3
45	BEARING	1
46	COLLAR	1
47	SCALE RING	1
48	HANDLE WHEEL	1
49	HANDLE	1
50	HANDLE	1
51	NUT	1
52	KEY	1
53	CLAMP BLOCK	1
54	CLAMP HANDLE	1
55	BOX	1

GEAR HEAD

NUMBERP	NAME	QUANTITY
F1	BOX	1
2	COLLAR	1
3	OIL SEAL	1
4	BALL BEARING	1
5	SCREW	1
6	O—RING	1
7	COLLAR	1
8	RETAINING RING	1
9	GEAR	1
10	KEY	1
11	RETAINING RING	1
12	SHAFT	1
13	KEY	1
14	DRIVING SHAFT	1
15	GEAR	1
16	RETAINING RING	1
17	SCREW	1
18	GEAR	1
19	GEAR	1
20	O—RING	2
21	BALL BEARING	1
22	COLLAR	1
23	COLLAR	1
24	BALL BEARING	1
25	RETAINING RING	1
26	GEAR	1
27	GEAR	1
28	COLLAR	1
29	GEAR	1
30	O—RING	1

NUMBERP	NAME	QUANTITY
31	DRIVING SHAFT	1
32	DRIVING SHAFT	1
33	SCREW	1
34	GEAR	1
35	GEAR	1
36	GEAR	1
37	KEY	1
38	BEARING	1
39	COLLAR	1
40	BOX COVER	1
41	COLLAR	1
42	BEARING	1
43	SCREW	4
44	COLLAR	3
45	BEARING	3
46	SCREW	6
47	PIN	2
48	MOTOR	1
49	GEAR	1
50	SCREW	1
51	BOLT	4
52	LIFT FORK	2
53	CRESCENT RING	2
54	PIN	2
55	SHAFT	2
56	O—RING	2
57	COLLAR	2
58	PIN	2
59	HANDLE	2
60	BALL	2
61	SPRING	1
62	OIL POSITION	1
63	BOLT	1
64	SCREW	2

NUMBERP	NAME	QUANTITY
G1	HANDLE	1
2	HANDLE COLLAR	1
3	NUT	1
4	KEY	1
5	WASHER	1
6	HAND WHEEL	1
7	SCREW	1
8	OIL COVER	1
9	SCALE RING	1
10	BALL BEARING	1
11	SCREW	1
12	OIL CUP	1
13	SUPPORT	1
14	WASHER	1
15	SCREW	1
16	NUT	1
17	SADDLE	1
18	TABLE	1
19	SCREW BRACKET	2
20	DOG	2
21	SCREW	2
22	LONG BEVEL IRON	1
23	ADJUST SCREW	1
24	BALL SCREW	1
25	SUPPORT	1
26	SCREW	4
27	OIL CUP	1
28	BALL BEARING	1
29	SCALE RING	1

NUMBERP	NAME	QUANTITY
30	SCREW	1
31	CONNECT TUBE	1
32	HAND WHEEL	1
33	WASHER	1
34	KEY	1
35	NUT	1
36	HADLE COLLAR	1
37	HANDLE	2
38	CLAMP BLOCK	2
39	PIN	2
40	SCREW	2
41	HAND BOARD	2
42	SCREW	3
43	WIPER PLATE	2
44	NUT	1
45	CLAMP BLOCK	2
46	SCREW	2
47	HANDBOARD	2
48	PIN	2
49	BEVEL IRON	1
50	ADJUST SCREW	1
51	BALL SCREW	1
52	BALL BEARING	1
53	OIL CUP	1
54	SUPPORT	1
55	SCREW	1
56	BALL BEARING	1
57	SCALE RING	1
58	SCREW	

Installation

FOUNDATION PLAN

Ideally this machine should be bolted to a concrete foundation. The machine should be placed on a solid level floor or anti-vibration pads to prevent any rocking movement.

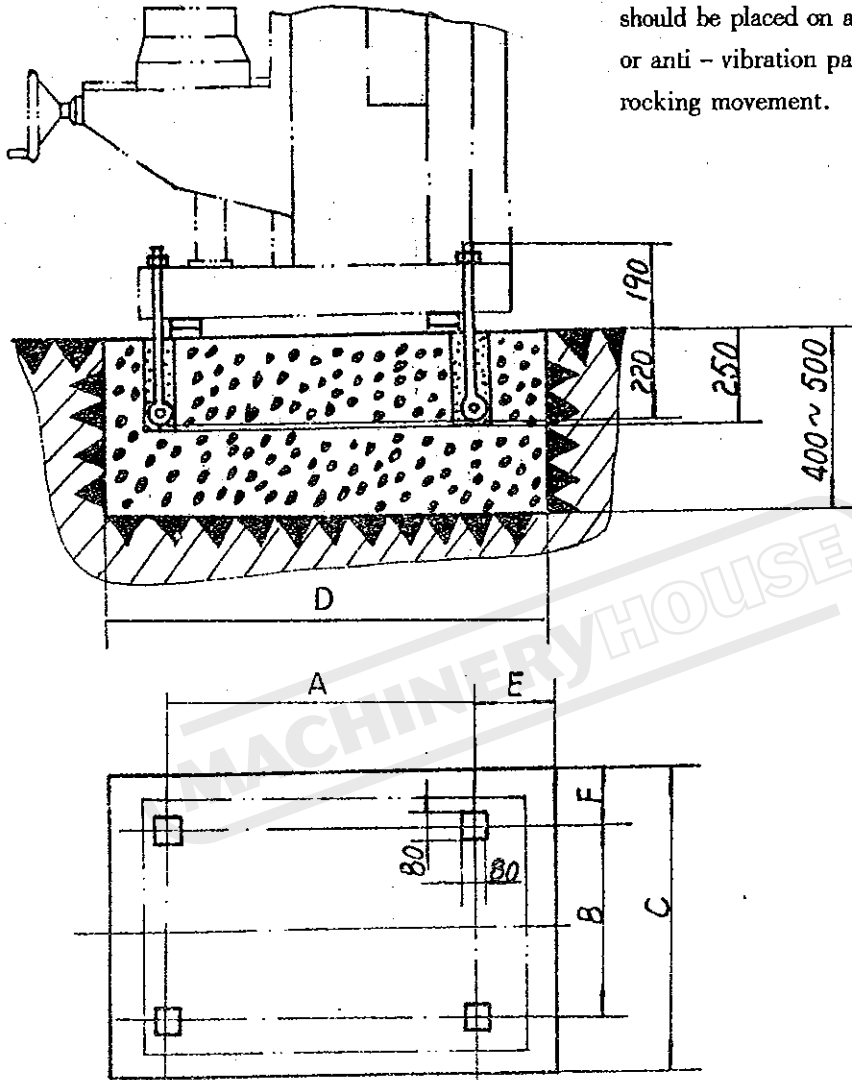

MODEL	A	B	C	D	E	F
HM50	678	445	745	1110	220	150
HM52'	845	466	760	1285	220	150

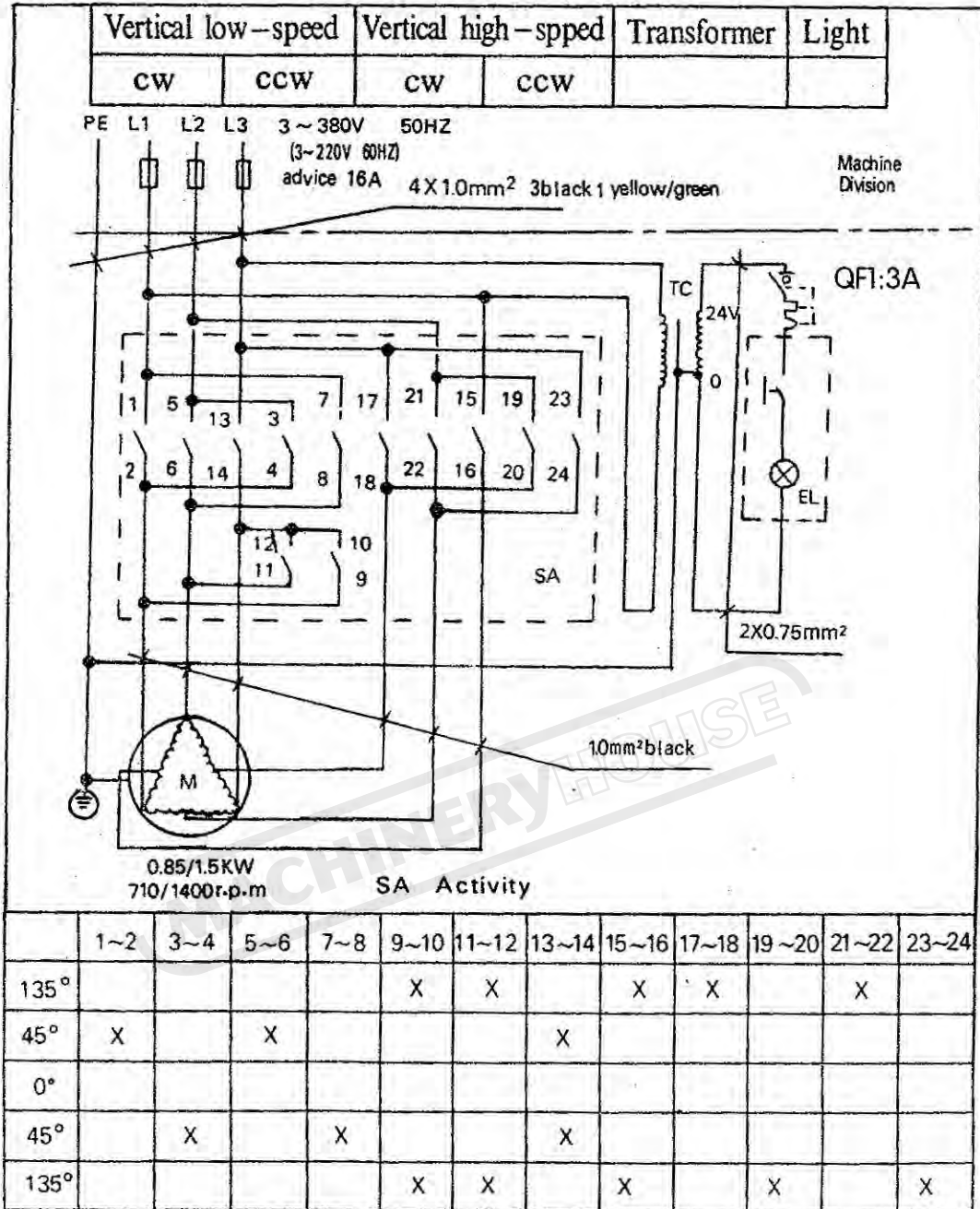

Used

When power voltage of 220V 60HZ, the motor's voltage, transformer's input and Ac contactor will be changed into 220V 60HZ, the others unchanged.

COMPONENTS LIST

Item	code	Name	Model or specification	Quantity	Note
1	M1	Three—phase induction motor (Vertical)	YD100L—8/4 3PH 380V 50HZ 0.85/1.5kw 710/1400r. p. m v1	1	
2	QF	Circuit breaker	DZ47—63(1P 3A)	1	
3	TC	Transformer	JBK4—63 63VA 0—220V I: 0—380V 0:0—24V 63VA	1	
4	SA1	Combination Switch (for vertical mill control)	LW5—16/5.5SN/6 Ue:500V Ie:16A	1	
5	EL	Light	JC11—1E27(AC: 24V 40W)	1	
		Halogen lamp	JC—38(50W AC: 24V)	1	optional accessory

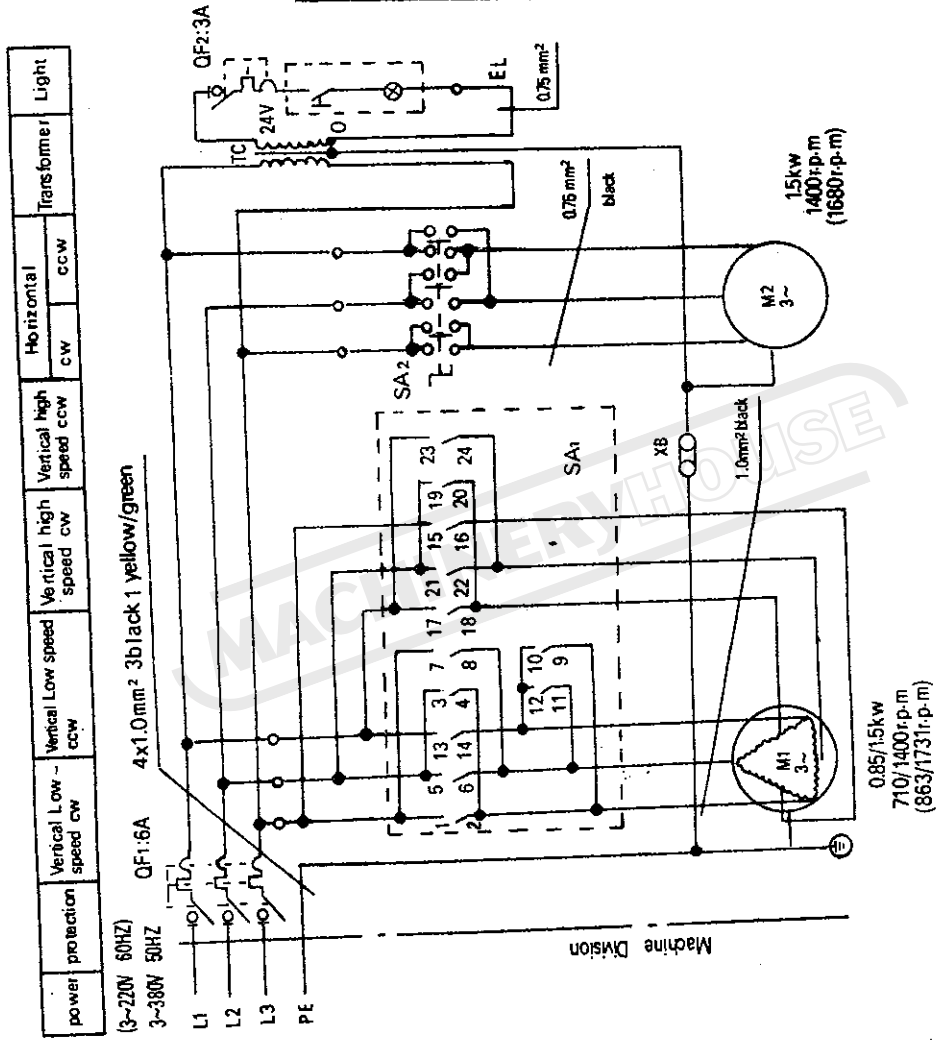

When power volatage of 220V 60HZ used, the motor's Volatage and the transformer's input will be changed into 220V 60HZ, the others unchanged.

COMPONENTS LIST

Item	code	Name	Model or specification	Quantity	Note
1	M1	Three—phase induction motor (Vertical)	YD100L—8/4 3PH 380V 50HZ 0.85/1.5KW 710/1400r. p. m V1	1	
2	M2	Three—phase induction motor (Horizontal)	Y90L—4 3PH 380V 50HZ 1.5KW 1400r. p. m B3	1	
3	QF1	circuit breaker	DZ47—63 (3P 6A)	1	
4	QF2	Circuit breaker	DZ47—63 (1P 3A)	1	
5	SA1	Combination Switch (for vertical mill control)	LW5—16/5.5SN/6 Ue:500V Ie:16A	1	
6	SA2	Combination Switch	HZ5B—10/3DO22 Ue:380V Ie:10A	1	
7	TC	Transformer	JBK4—63 63VA I: 0—220V 0—380V D:0—24V 60VA	1	
8	EL	Light	JC11—1E27 (AC; 24V 40W)	1	
		Halogen lamp	JC—38 (AC:24V 50W)	1	optional accessory

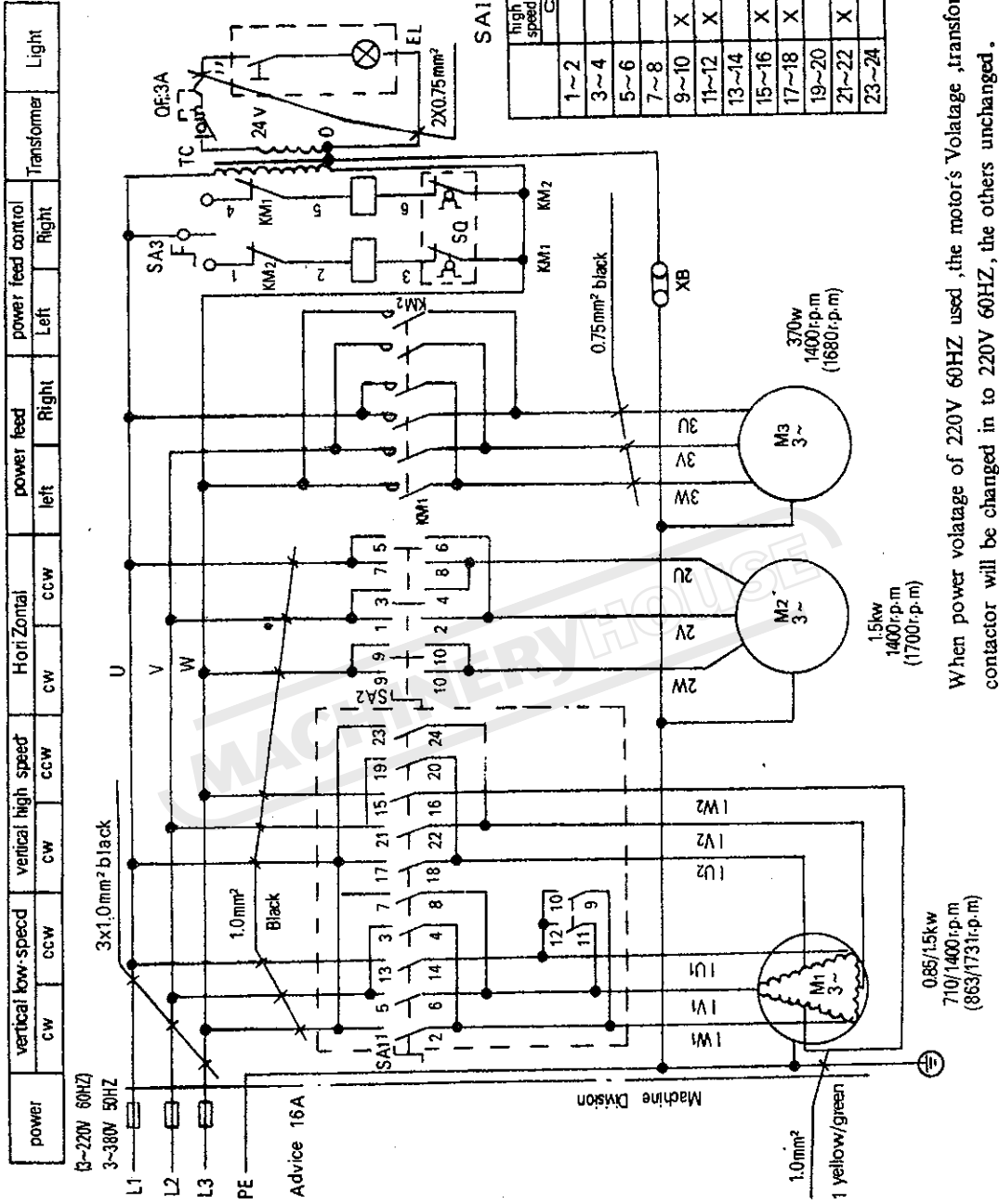

SAI Activity

	High speed		LOW speed		Off
	GW	CCW	GW	CCW	
1~2		X			
3~4			X		
5~6				X	
7~8					X
9~10	X				
11~12	X				
13~14			X		
15~16				X	
17~18			X		
19~20				X	
21~22	X				
23~24					X

When power voltage of 220V 60HZ used, the motor's Voltage, transformer's input and Ac contactor will be changed in to 220V 60HZ, the others unchanged.

COMPONENTS LIST

Item	code	Name	Model or specification	Quantity	Note
1	M1	Three—phase induction motor (Vertical)	YD100L—8/4 3PH 380V 50HZ 0.85/1.5KW 710/1400r. p. m V1	1	
2	M2	Three—phase induction motor (Horizontal)	Y90L—4 3PH 380V 50HZ 1.5KW 1400r. p. m B3	1	
3	M3	Three—phase induction motor (power feed)	YS—7124 AC;3PH 380V 50HZ 370W 1400r. p. m B5	1	
4	KM1 KM2	AC contactor	CJX1—9/22 AC;380V 50HZ	2	
5	SA1	Combination Switch (for vertical mill control)	LW5—16/5.5SN/6 Ue;500V Ie;16A	1	
6	SA2	Combination Switch (for Horizontal mill control)	HZ5B—10/3DO22 Ue;380V Ie;10A	1	
7	SA3	Combination Switch (for power feed control)	LA18—22X3 Ie;5A	1	
8	QF	Circuit breaker	DZ47—63 (1P 3A)	1	
9	TC	Transformer	JBK4—63 60VA 0—220V I:0—380V D:0—24V 60VA	1	
10	EL	Light	JC11—1E27 (AC; 24V 40W)	1	
		Halogen lamp	JC—38 (AC;24V 50W)	1	optional accessory

power: power switch	vertical low-speed	vertical high-speed	power feed left	power feed right	power feed control	protection E-stop	Transformer	Light
3-220V 60HZ	CW	CW	left	right	Left stop	Right stop		
3-380V 50HZ	CCW	CCW						

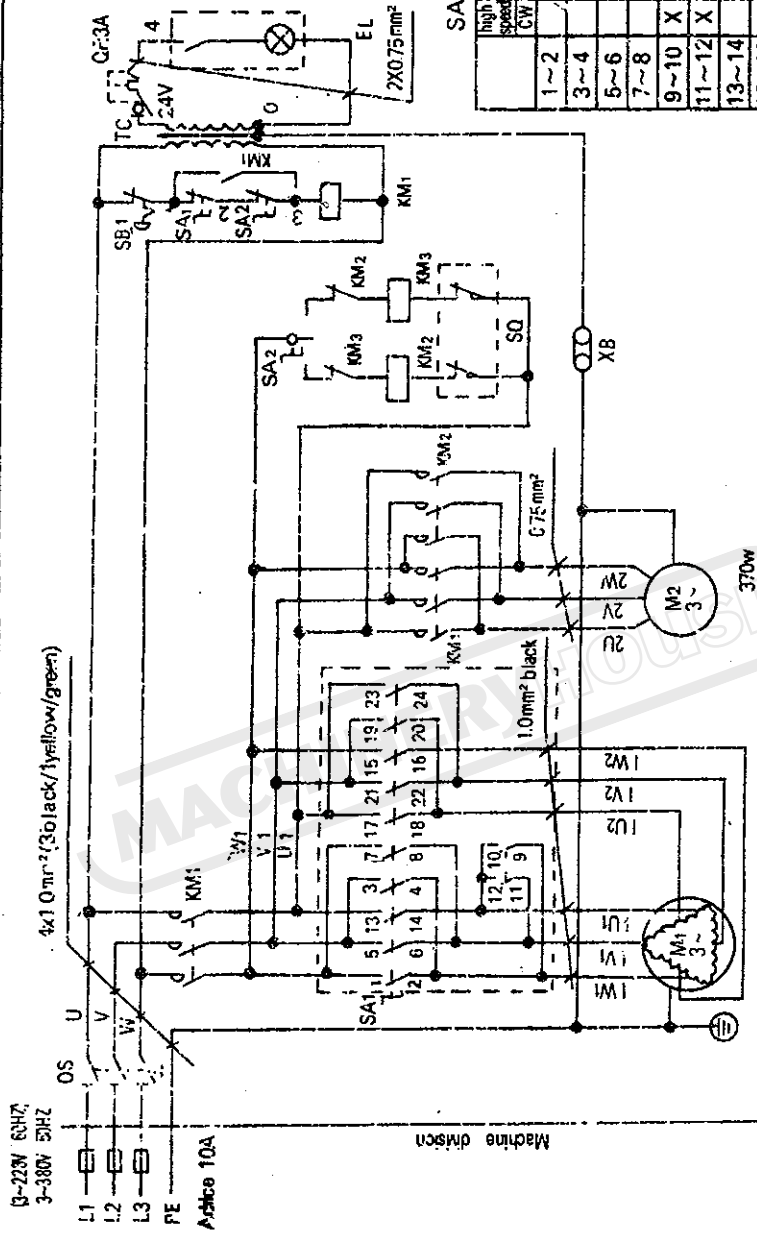

SA1 Activity

	high speed CW	LOW speed CW	OFF	LOW speed CCW	OFF	high speed CCW
1~2	X					
3~4		X				
5~6			X			
7~8				X		
9~10	X					X
11~12	X					X
13~14		X				
15~16	X					X
17~18	X					X
19~20						X
21~22	X					X
23~24						X
25~26	X					X
27~28						

Machine driven

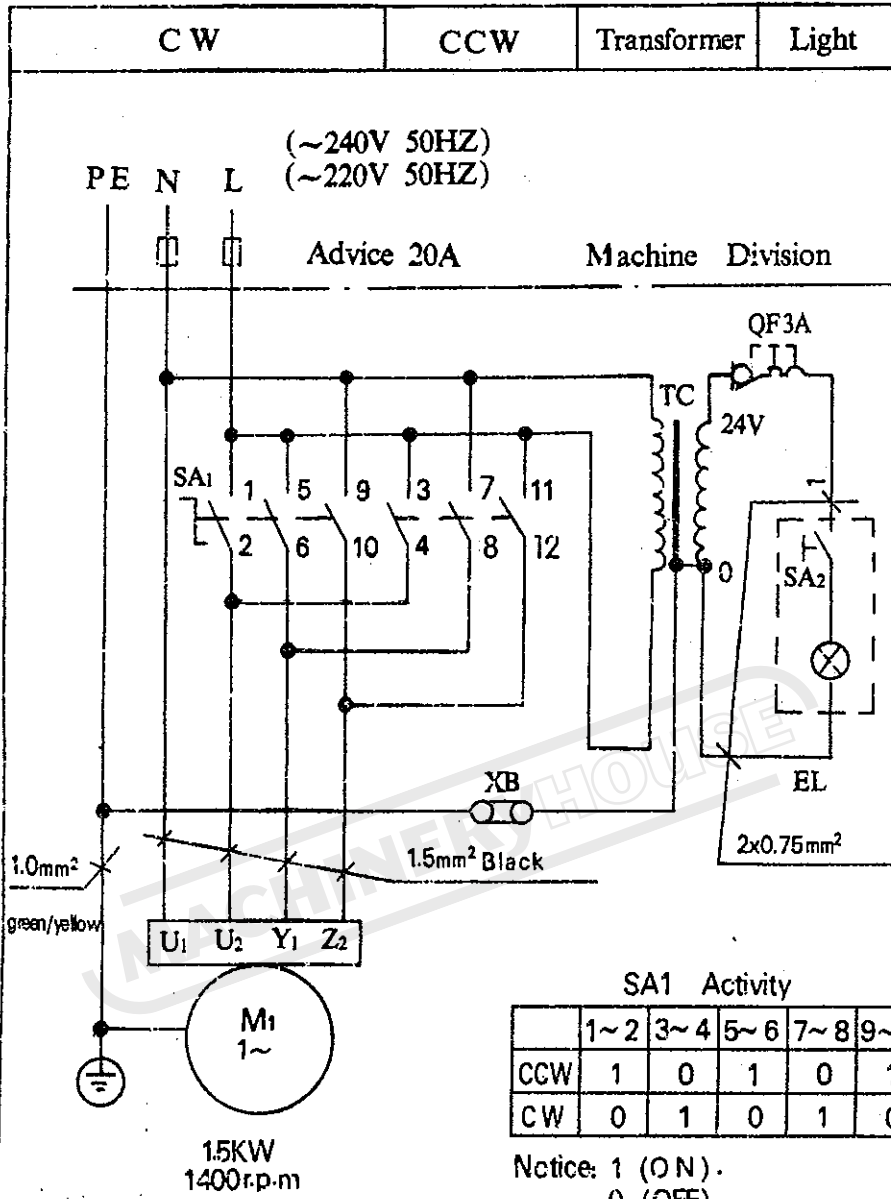

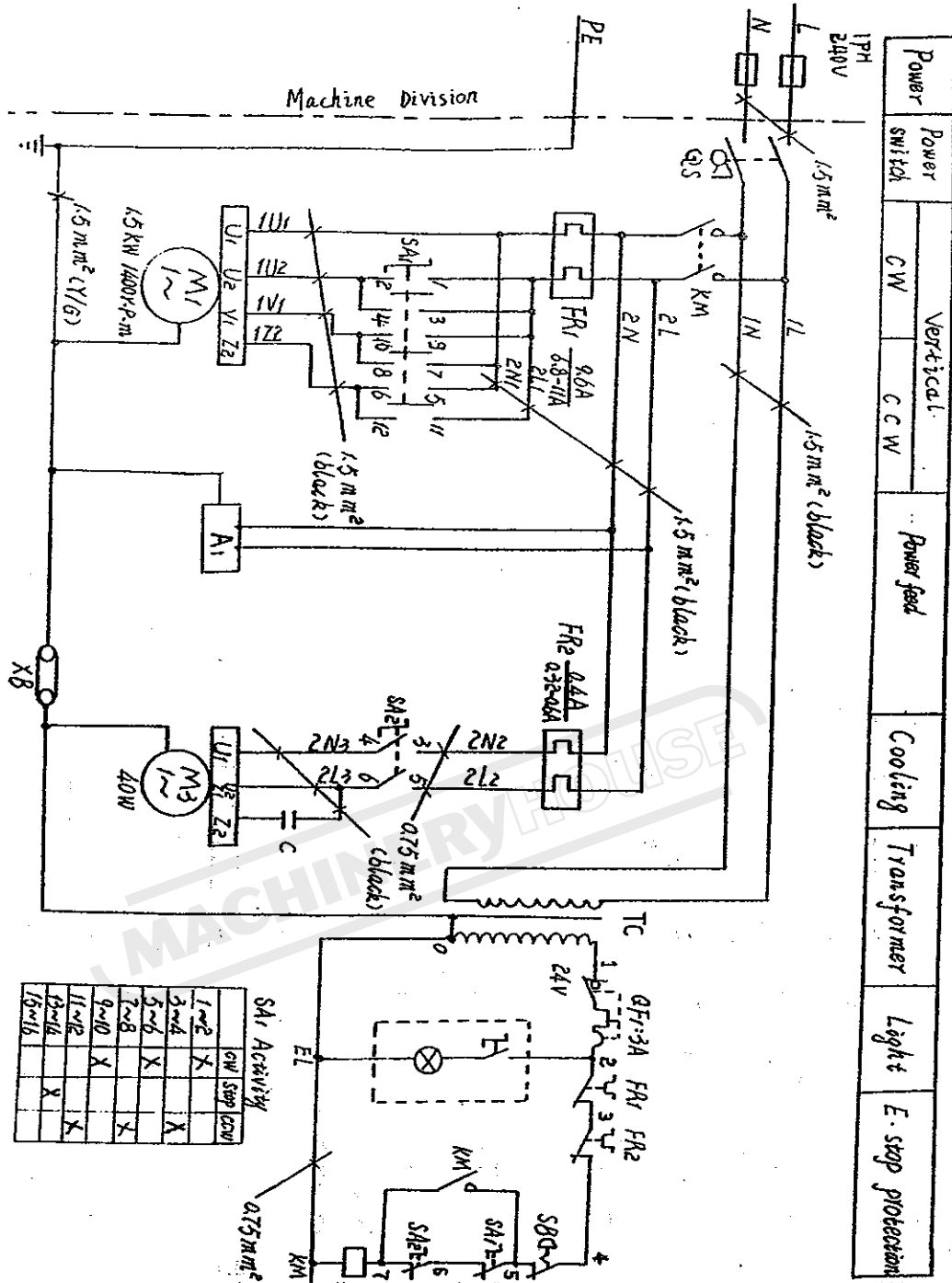

Power switch	Vertical	Power feed	Cooling	Transformer	Light	E-stop protection
	CW	C C W				

SA1 Activity	
OW	SBP (CN)
1~2	X
3~4	X
5~6	X
7~8	X
9~10	X
11~12	X
13~14	X
15~16	X

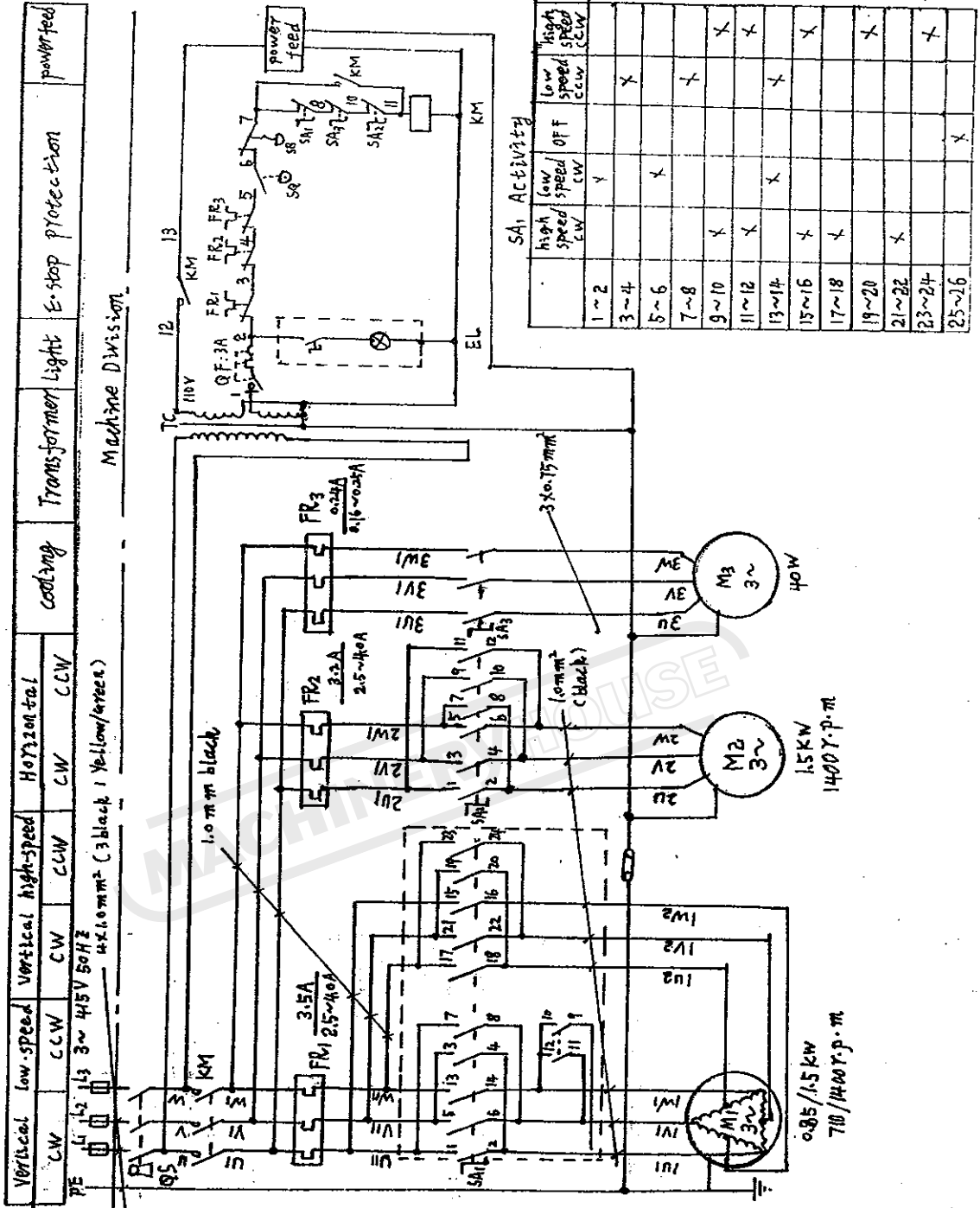

DRILLING & MILLING MACHINE

QUALITY CERTIFICATE

MACHINERYHOUSE

Accuracy Testing List				
1	Flatness	A Horizontal B Cross	0.04/1000 0.04/1000	/
2	Work flatness		0.04/200	0.03
3	Run out of spindle bore	A. End spindle face B. 300mm to spindle face	0.02 0.04	0.01 0.03
4	Kick of spindle		0.02	0.05
5	The perpendicular between spindle and table	A Longitudinal B cross	0.10/200 0.10/200	0.04 0.07
6	The perpendicular between Vertical movement of spindle and table	A longitudinal B Cross	0.10/100 0.10/100	0.05 0.07
7	The parallelism between the work flatness and table	A Longitudinal B Cross	0.05/200 0.05/200	0.03 0.04
8	The straightness of basis "T"		0.03/200	0.02
9	The parallelism between basis "T" and table		0.15/200	0.11
10	The perpendicular between longitudinal move of table and cross move of table.		0.10/200	0.08
11	straightness of vertical movement of knee	A longitudinal B Cross	0.05/200	0.05
12	The perpendicular between bedway and vertical guideway	A longitudinal B Cross	0.10/200 0.10/200	0.04 0.07
13	The parallelism between table and ram moving		0.10/200	0.05
14	The parallelism between table and roating plate rotate	left 30° 0° right 30°	0.10/200	0.04 0.07
15	The parallelism between spindle and worktable		0.10/200	/
16	The parallelism between cross move of work table and spindle	A longitudinal B Cross	0.10/200 0.10/200	/
17	The parallelism between the guideway of ram and spindle	A longitudinal B Cross	0.10/200 0.10/200	/
18	Coaxialism between the hole of surporthilt and axis of spindle	A longitudinal B Cross	0.10 0.10	/